

Assembly/Mounting Instructions

Clarion Permanently Tensioned Projection Screen by Draper

Caution

- ① Read instructions through completely before proceeding.
- ② Follow instructions carefully. Installation contrary to instructions invalidates warranty.
- ③ **When lifting assembled screen, do not lift at only one corner; lift at both corners. Lifting by one corner could result in damage to the screen frame, especially on large screens.**
- ④ Screen should be accessible for complete removal should fabric become damaged or should other service be required.
- ⑤ Screen should be installed level (using a carpenter's level).
- ⑥ Nothing should be fastened to screen frame or viewing surface.
- ⑦ Make sure you have received all parts (see parts list below and exploded diagram on page 2).
- ⑧ Screwdriver required for screen assembly; drill and screwdriver needed for attachment to wall.

NOTE: Screen has been thoroughly inspected and tested at factory and found to be operating properly prior to shipment.

Clarion—Hardware and Parts List

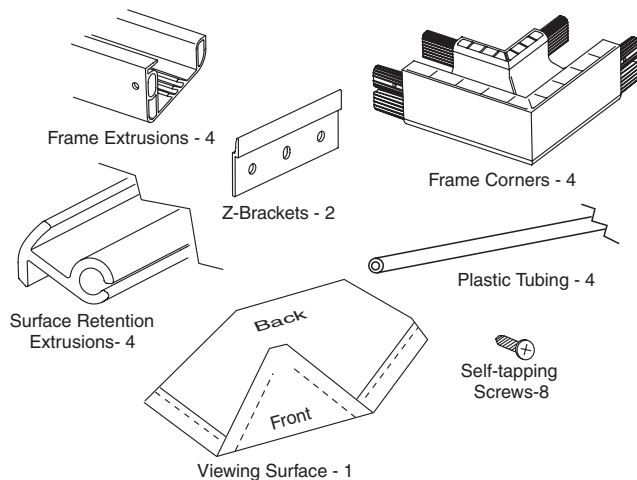

Frame Preparation

- ① Clean area and place frame assembly pieces face down. Snap plastic corner pieces into ends of aluminum frame extrusions as indicated in Figures 1 through 4.

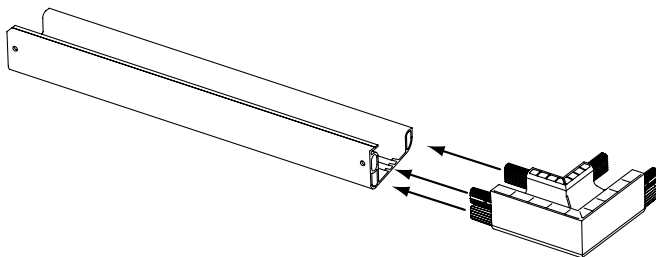

Figure 1

Patented by Draper, Inc., U.S. Patent No. 6,785,047. Other patents pending.

DRAPER

411 S. Pearl St., Spiceland, IN 47385 USA ■ 765-987-7999 ■ fax 765-987-7142
 e-mail draper@draperinc.com ■ www.draperinc.com

Copyright © 2006 Draper Inc.

Form Clarion_Instance06

Printed in U.S.A.

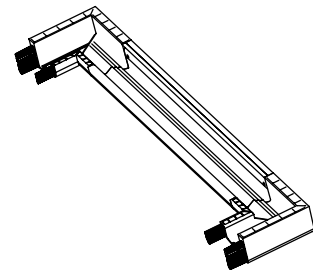

Figure 2

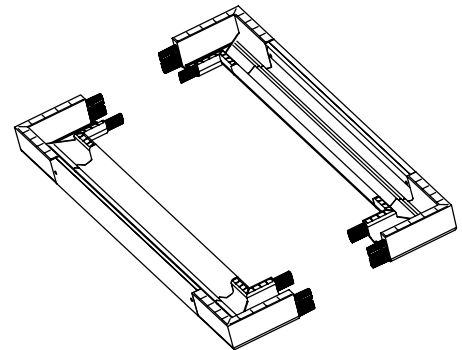

Figure 3

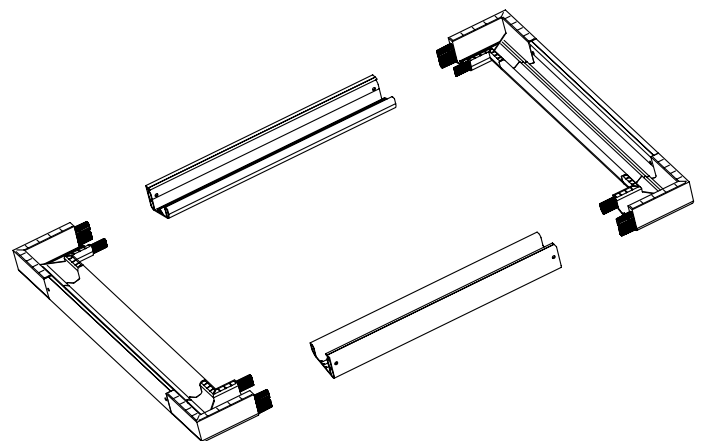

Figure 4

- ② Check to verify that all four (4) plastic corners are seated securely in aluminum frame extrusion lengths (see Fig. 5). Lock in place using eight (8) self-tapping screws .

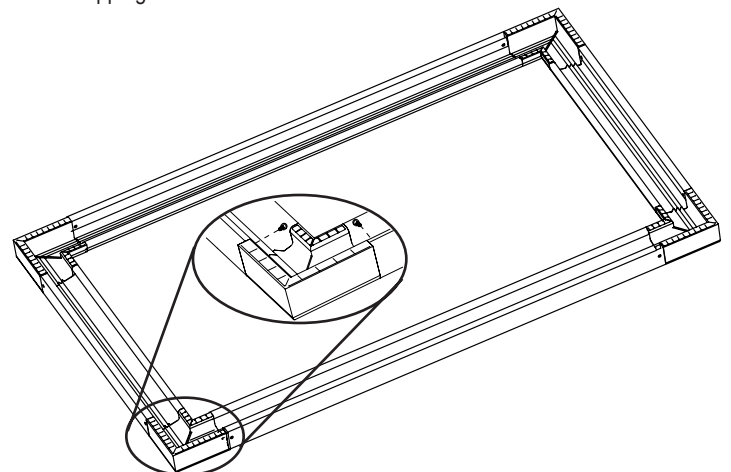

Figure 5

(Continued on Page 2)

If you encounter any difficulties installing or servicing your Clarion screen, call your dealer or Draper, Inc., Spiceland, Indiana, (765) 987-7999; draper@draperinc.com.

Surface Preparation

- ① Move frame assembly out of the way, unroll viewing surface and place on smooth/clean surface. (Orient viewing surface so that folded side of hem is visible.)
- ② Insert plastic tubing inside pocket formed by hem on all 4 edges of viewing surface (see Fig. 6).

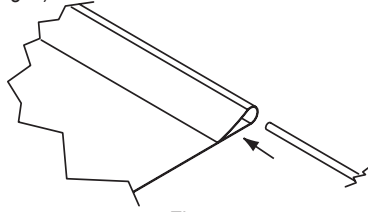

Figure 6

- ③ **Carefully** slide surface retention extrusion (rounded edge visible) along hem and onto surface on all 4 edges of fabric (see Fig. 7). **Caution: Do not allow fabric to snag on the ends of the extrusions. If the screen fabric is not parallel with the surface retention extrusion, then it may slit and tear during installation.** **Please Note: To make this step easier, pinch the end of the pocket closed before sliding it into the surface retention extrusion.**

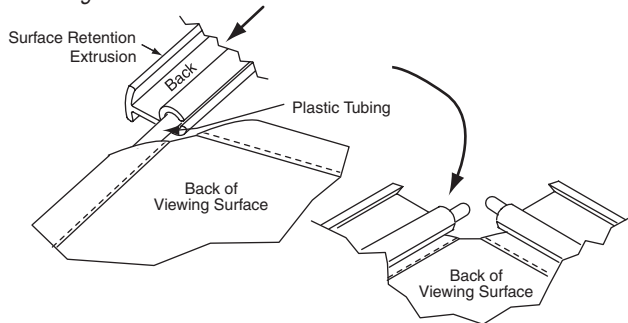

Figure 7

- ④ Surface retention extrusion should extend beyond edge of viewing surface equally at both ends.
- ⑤ Verify that all surface retention extrusions are installed with rounded edge visible and are centered on surface material.

Surface to Frame Assembly

- ① Return frame onto clean surface, face down, and drape completed surface assembly over completed frame profile with rounded edge of surface retention extrusion visible.
- ② Insert any side of surface to notch #1 on corresponding side of frame extrusion (see Fig. 8).

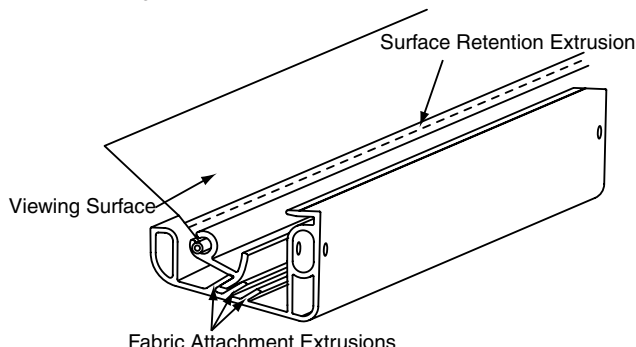

Figure 8

- ③ Insert opposite side of surface to notch #1 of frame extrusion.
- ④ Repeat steps 2-3 with remaining edges of surface.
- ⑤ Ensure surface retention extrusions are centered lengthwise in tension slots on all 4 edges of surface.
- ⑥ If additional tension is desired or required over time, adjust surface one edge at a time to tension notch #2.

Please Note: It is not necessary to adjust more than one edge at a time to increase surface tension.

Mounting Screen to Wall

- ① Determine height at which screen is to be mounted. **Please Note: Top edge of screen frame will be located 1/2" above mounting bracket hole centerline when mounted to wall.**
- ② Mark hole centerline so that both Z-brackets can be mounted parallel and at equal height.
- ③ Install Z-brackets so that the outermost edges are safely within the overall length of the aluminum frame extrusion to allow for minor horizontal screen adjustments (hardware for mounting Z-brackets to wall is not supplied).
- ④ Position screen slightly above Z-brackets on wall (see Fig. 9). **Please Note: When lifting screen, do not lift at only one corner; lift at both corners. Lifting by one corner could result in damage to the screen frame, especially on large screens.**

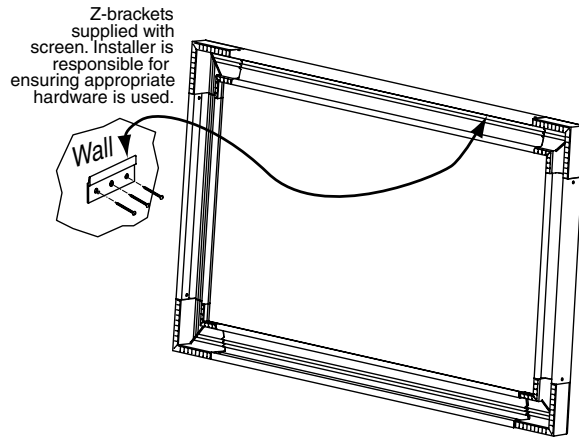
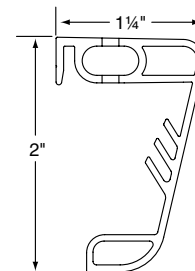

Figure 9

- ⑤ Lower screen until it engages over Z-brackets. Center screen horizontally on brackets as necessary. **Please Note: Make sure screen is installed level.**

Clarion Frame—Side Detail*



*Viewing surface is approximately 1/4" from wall.

Clarion (Exploded Rear View)

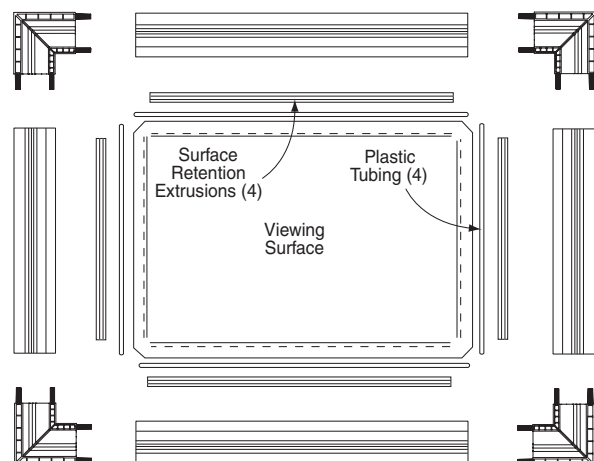

Please Note: To avoid damage to the frame corners, be sure to support a minimum of two (2) corners when lifting or transporting screen.

Assembly/Mounting Instructions

Addendum for Large Clarion Screens by Draper

Caution

- ① Read instructions through completely before proceeding.
- ② Follow instructions carefully. Installation contrary to instructions invalidates warranty.
- ③ Make sure you have received all parts.
- ④ Be careful when inserting and sliding brace. The viewing surface could be damaged if the brace comes in contact with the viewing surface.

Please Note: Be careful when inserting and sliding brace. The viewing surface could be damaged if the brace comes in contact with the viewing surface.

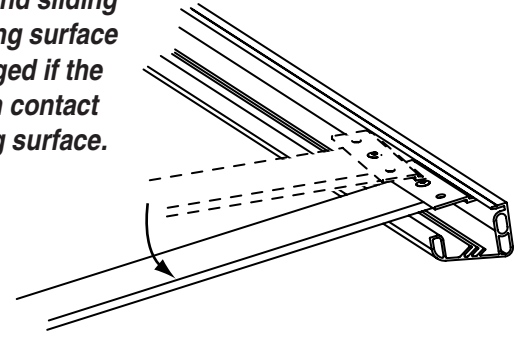

Figure 1

Attaching Braces to Frame

- ① Insert vertical brace into groove on back side of frame, so that tongue fits into slot. Make sure the rivet faces up (away from the screen and frame). Insert one end of the brace into one groove at a slight angle, then rotate other end of brace into groove until the vertical brace is parallel with the frame sides (see Fig. 1). Braces will remain in place; no fasteners are required.
- ② For large Clarions, one or two vertical braces may be required. For a single vertical brace, center brace on back of screen frame (see Fig. 2). For two braces, place each brace approximately one-third of the way in from the sides of the frame (see Fig. 3).

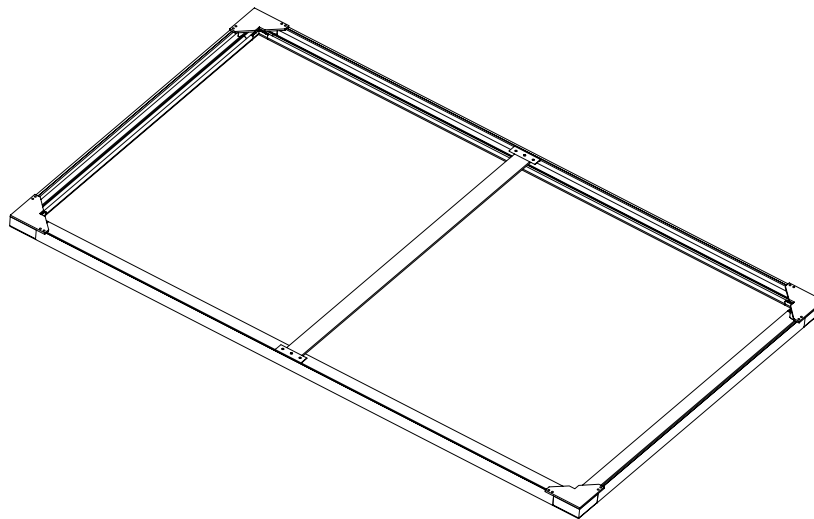

Figure 2

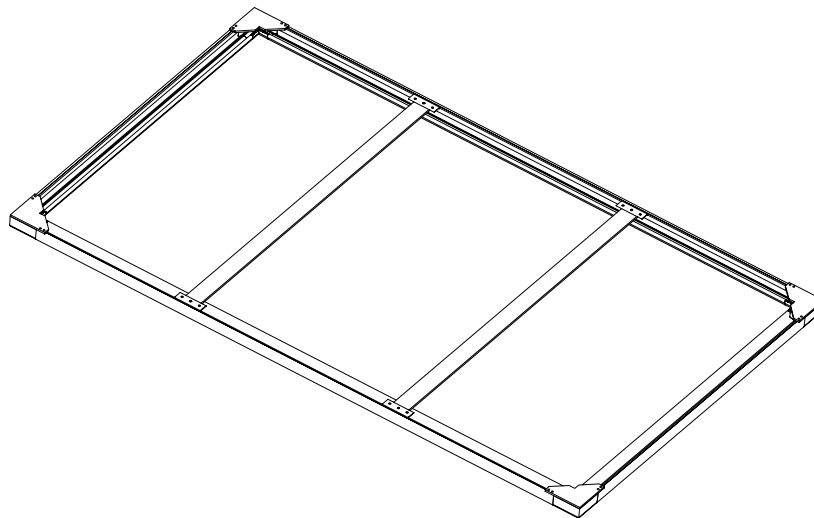

Figure 3

DRAPER

411 S. Pearl St., Spiceland, IN 47385 USA ■ 765-987-7999 ■ fax 765-987-7142
e-mail draper@draperinc.com ■ www.draperinc.com

Copyright © 2006 Draper Inc.

Form Clarion-Addendum_Inst06-R

Printed in U.S.A.

If you encounter any difficulties installing or servicing your Clarion screen, call your dealer or Draper, Inc., Spiceland, Indiana, (765) 987-7999; draper@draperinc.com.