

INSTRUCTIONS

DirectConnect®
IRCB4 Connecting Block



Helping you achieve your installation needs!

Model: IRCB4
SKU# .11820

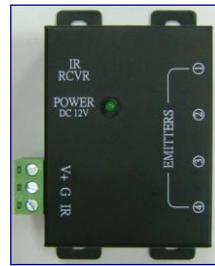

Features:

- Four emitter output connections
- Power receptacle with LED indicator
- Removable Connector for system connection

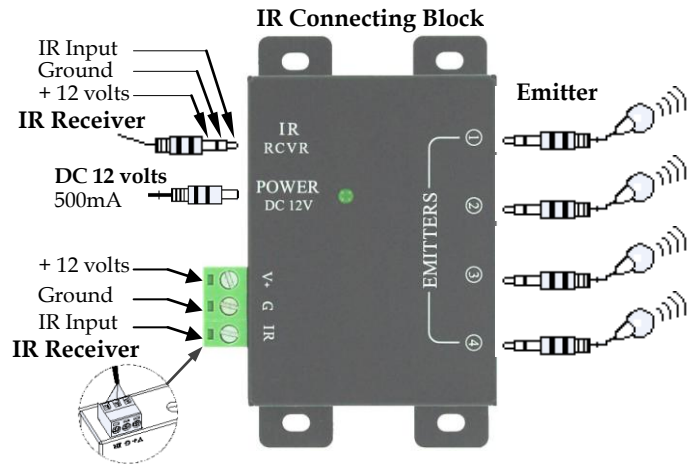

Installation

Power: Connect a 12 VDC 500 mA power supply (not included) to the power jack. (2.1mm + tip -sleeve)
The green LED will be illuminated when powered. This will power all of the IR components connected to the system.

System Connection: Connect the IR system to the detachable connector printed V+ (12VDC), G (Ground), and IR (Signal).

Emitter Outputs: Choosing compatible parts -IRE1 (MINATURE IR SINGLE EMITTER) or IRE2 (MINATURE IR DUAL EMITTER), connect up to 4 emitters to the emitter jacks marked 1-4. Place the emitters on the source equipment.

Mounting: Mount /adhere IR emitters over the source equipment IR receiver.

DirectConnect® products are manufactured in accordance with our rigorous and exact specifications, are thoroughly inspected, and meet or exceed the Underwriters Laboratories Inc. (UL) verification of performance where applicable. The specifications for this product and the specific country of origin for this product are available upon request. As a result, DirectConnect® fully guarantees our IR products for one (1) year from the date of purchase, against all defects in material and workmanship. During the 1-year period, DirectConnect® will replace defective product without charge provided it was installed under industry standard installation practices and not subject to misuse or abuse. Specifically, this warranty is subject to the following additional conditions and limitations: the warranty is void and inapplicable if DirectConnect® judges the product has been used or handled other than in accordance with instructions or standard practices, including, but not limited to damage caused by accident, mishandling, improper installation, negligence and/or has defects caused by *force majeure* or Acts of God. If the above conditions are met, the purchaser's sole remedy is to return the product to DirectConnect®, which will replace the defective product without charge for parts or labor, and return by shipping the same by its usual shipping method at its expense within the United States of America.

THERE ARE NO OTHER WARRANTIES, INCLUDING WITHOUT LIMITATION, EITHER EXPRESS OR IMPLIED WARRANTIES OF MERCHANTABILITY OR FITNESS FOR A PARTICULAR PURPOSE WITH RESPECT TO THE PRODUCT. REPLACEMENT AS PROVIDED UNDER THIS WARRANTY IS THE EXCLUSIVE REMEDY OF THE PURCHASER. DIRECTCONNECT SHALL NOT BE RESPONSIBLE FOR ANY INCIDENTAL OR CONSEQUENTIAL DAMAGES EXCEPT TO THE EXTENT PROVIDED OR PROHIBITED BY APPLICABLE LAW.

Some states do not allow the exclusion or limitation of incidental or consequential damages, so the above limitation may not apply. This warranty gives you specific legal rights and you may also have other rights, which vary from state to state.

All DirectConnect® products are manufactured and packaged for in accordance with exact specifications. To make a claim under this warranty or to request product information or specifications, contact DirectConnect, 4747 Westpark Drive, Houston, TX, 77027.

Would it make your day to know that someone is waiting to hear from you? We are.
Your DirectConnect® representative is ready to take your call.
Or if you prefer, contact us online at ...
sales@directconnecthome.com